



**HITACHI**

Hosted by: 國家鐵路局  
National Railway Administration of the People's Republic of China

機電工程署  
EMSD

MTR



**IRSC 2025**

*Advancing Railway Safety through  
Innovations and Collaborations*

*Hong Kong, China 25<sup>th</sup> - 30<sup>th</sup> November 2025*

# Securing CBTC on HKIA APM with 5G

Nicolas Rabbat  
CEO  
Hitachi Rail  
Hong Kong

Joseph Lam  
General Manager, Technical  
Services Systems  
Airport Authority Hong Kong



# 5G-Based Comms for Railway Operations



Hosted by: 國家鐵路局  
National Railway Administration of the People's Republic of China

機電工程署  
EMSD



MTR



HITACHI

# MULTISERVICE NETWORK FOR URBAN RAIL OPERATIONS

---



# Agenda

- Introduction
- Solution
- Implementation Challenges
- Benefits
- Collaboration



**Sub-theme: Securing CBTC on HKIA APM with 5G**

Hosted by:



**HITACHI**



# Introduction

Hong Kong International Airport has trusted SelTrac™ CBTC for its driverless Automated People Mover (APM) since 2012. In 2023, Hitachi Rail has been awarded the delivery of a **5G overlay network** in addition of the existing 2.4 GHz radio access network.

The new 5G system provides train to-ground communications – will play a critical role in delivering reliable and high-capacity CBTC operations.



**Sub-theme: Securing CBTC on HKIA APM with 5G**

Hosted by:



機電工程署  
EMSD



**HITACHI**

# Why 5G for Urban Rail Signalling

## A game changer for urban rail signalling

- **Performance and reliability** – The 5G radio allows continuity of service and non-stop connectivity, whatever the speed and the environment.
- **Infrastructure optimisation** - We optimise our architectures to deliver high-performance and future-ready infrastructures that support both backward and forward compatibility.
- **Safe and seamless deployment** – With extensive operational experience, we understand deployment constraints, allowing a safe and seamless deployment.
- **Cyber-secured** - The solution are designed with an end-to-end security architecture to ensure cyber security.



**Performance & Reliability**  
Continuity of service



**Infrastructure Optimization**  
Cost efficiency  
Backwards/forwards compatibility



**Safe & Seamless deployment**  
Extensive operational experience



**Cyber-secured**  
By design



**Sub-theme: Securing CBTC on HKIA APM with 5G**

Hosted by:



機電工程署  
EMSD



**HITACHI**

# Full 5G Coverage in APM Operation Area

Peak sector throughput on various antenna designs:

Sector coverage	Antenna design	Downlink	Uplink
APM Tunnel	Leaky cable (2T2R)	100Mbps <sup>(1)</sup>	30Mbps
APM Depot	pRRU (4T4R)	150Mbps	30Mbps <sup>(2)</sup>
APM Platforms			

## Remarks:

- (1) Higher channel efficiency due to lower interference
- (2) Most end devices only support 2T uplink

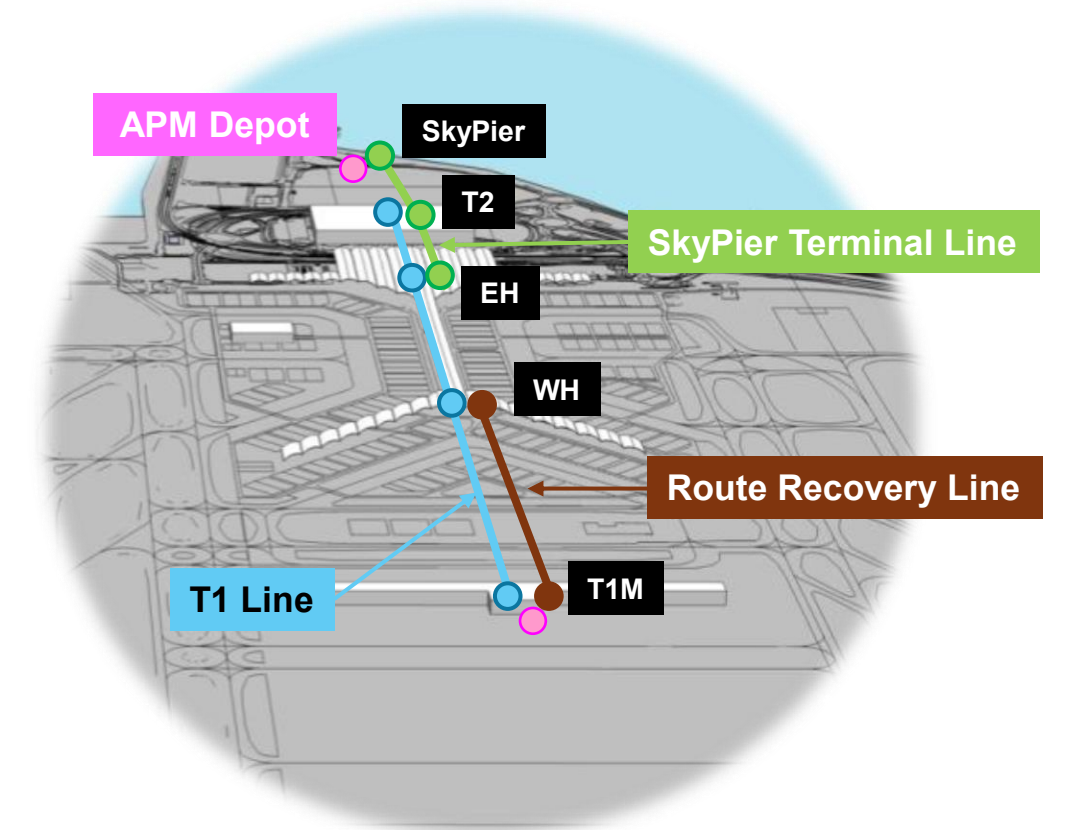

Sub-theme: Securing CBTC on HKIA APM with 5G

Hosted by:



機電工程署  
EMSD



MTR



HITACHI

# Securing CBTC on HKIA APM with 5G

Delivering the Future of Mobility

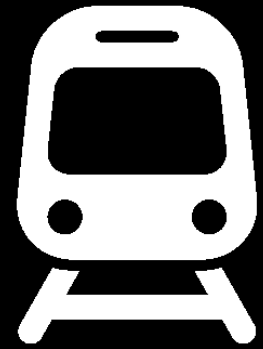

**21** vehicles are fully functional with 5G infrastructure



Project delivered on time and deployed without any operational impact



Sub-theme: Securing CBTC on HKIA APM with 5G

Hosted by:



機電工程署  
EMSD



HITACHI

# Solution

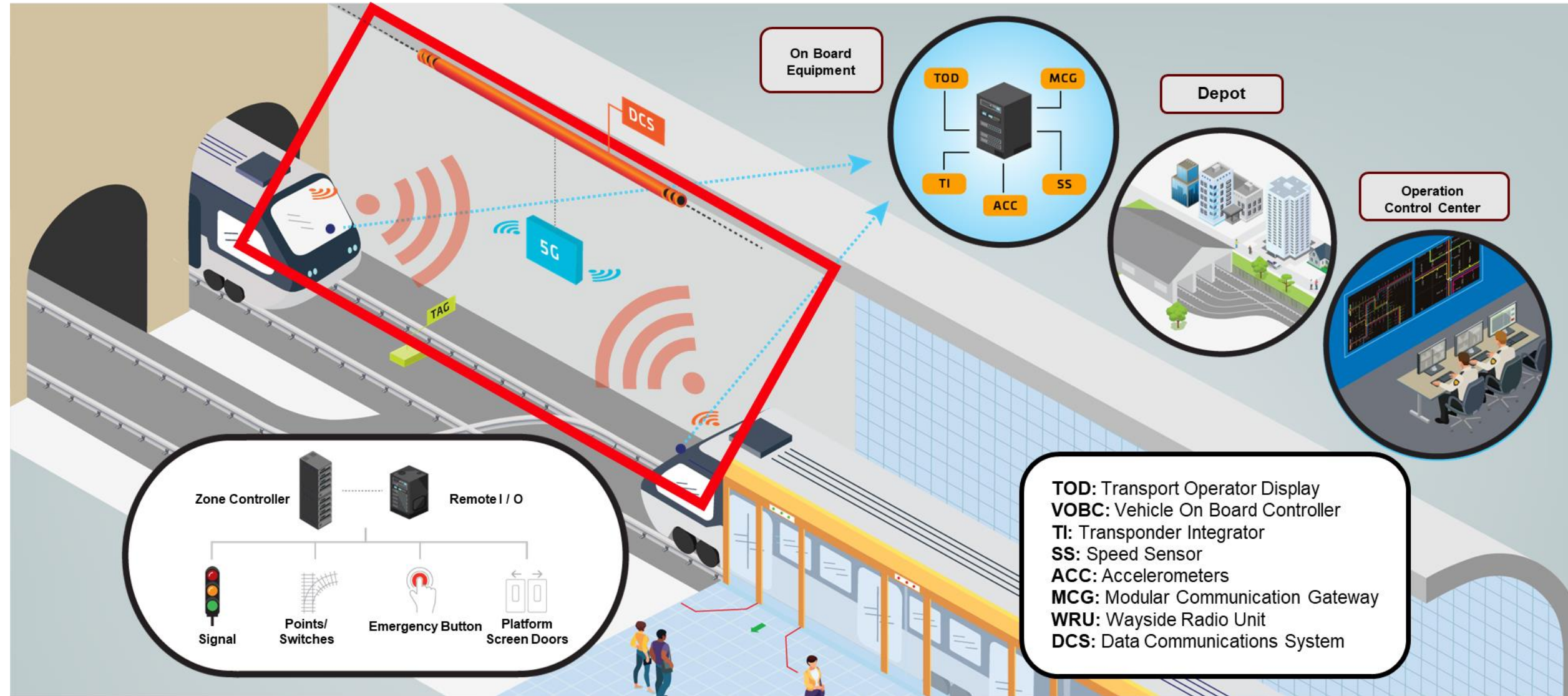

## SelTrac™ CBTC System Architecture

- Private 5G as a **critical communication layer**
- Connects Train Borne, Wayside and Central Servers



Sub-theme: Securing CBTC on HKIA APM with 5G

Hosted by:



機電工程署  
EMSD



HITACHI

# CBTC Architecture (over 5G)

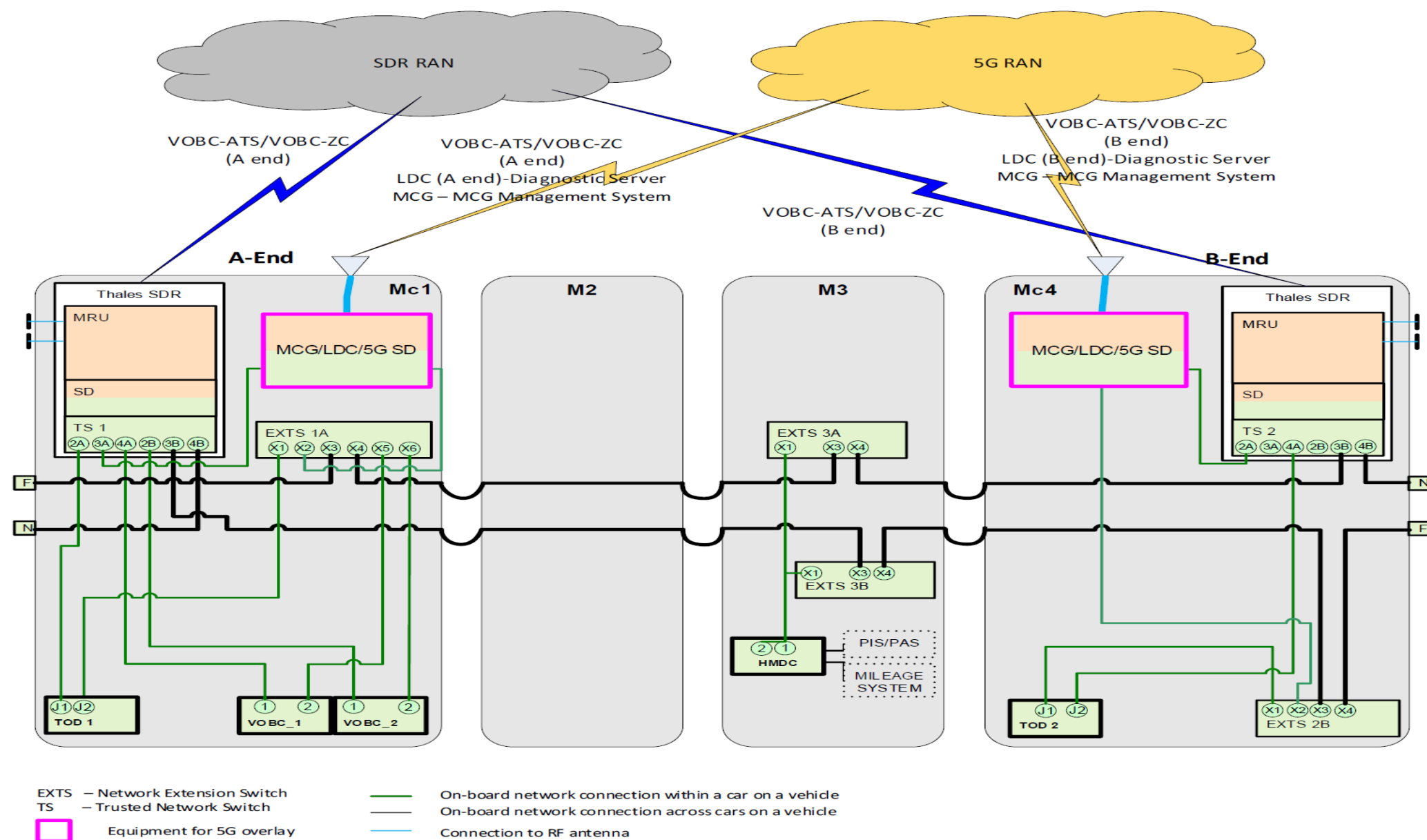

- **Moderated Communication Gateway (MCG) manages and coordinates all the traffics (Wi-Fi and 5G) on each train**
- **Simultaneous communication layers (Wi-Fi and 5G)**
- **Parallel data transmission using FIFO and proprietary message tagging**
- **Provides real-time performance monitoring and remote CBTC system logging**
- **Supports “on-the-go” rolling stock performance monitoring**

Introduced unified Gate Way (Moderated Communication Gateway)



**Sub-theme: Securing CBTC on HKIA APM with 5G**

Hosted by:



機電工程署  
EMSD



HITACHI

# CBTC Architecture (over 5G)

- Enhanced the existing System with **simultaneous communication layers** (Private 5G and Wi-Fi)
- Enhanced the redundancy** of communication through Secured Digital Radio (SDR) with Remote Access Network (RAN) being replicated and transmitted through the Private 5G RAN.
- Secured the SelTrac™ CBTC communications with 5G RAN as a **single private network** with :
  - Network Traffic not routable to the Internet or public 5G cellular network
  - Statically allocated IP addresses
  - Dedicated access point names (APN) for CBTC
  - Quality of service Identifier (5QI) w/ guaranteed bit rate and latency
  - Allocation and retention priority (ARP)
  - IPSec by VPN tunneling
  - IPS Firewall

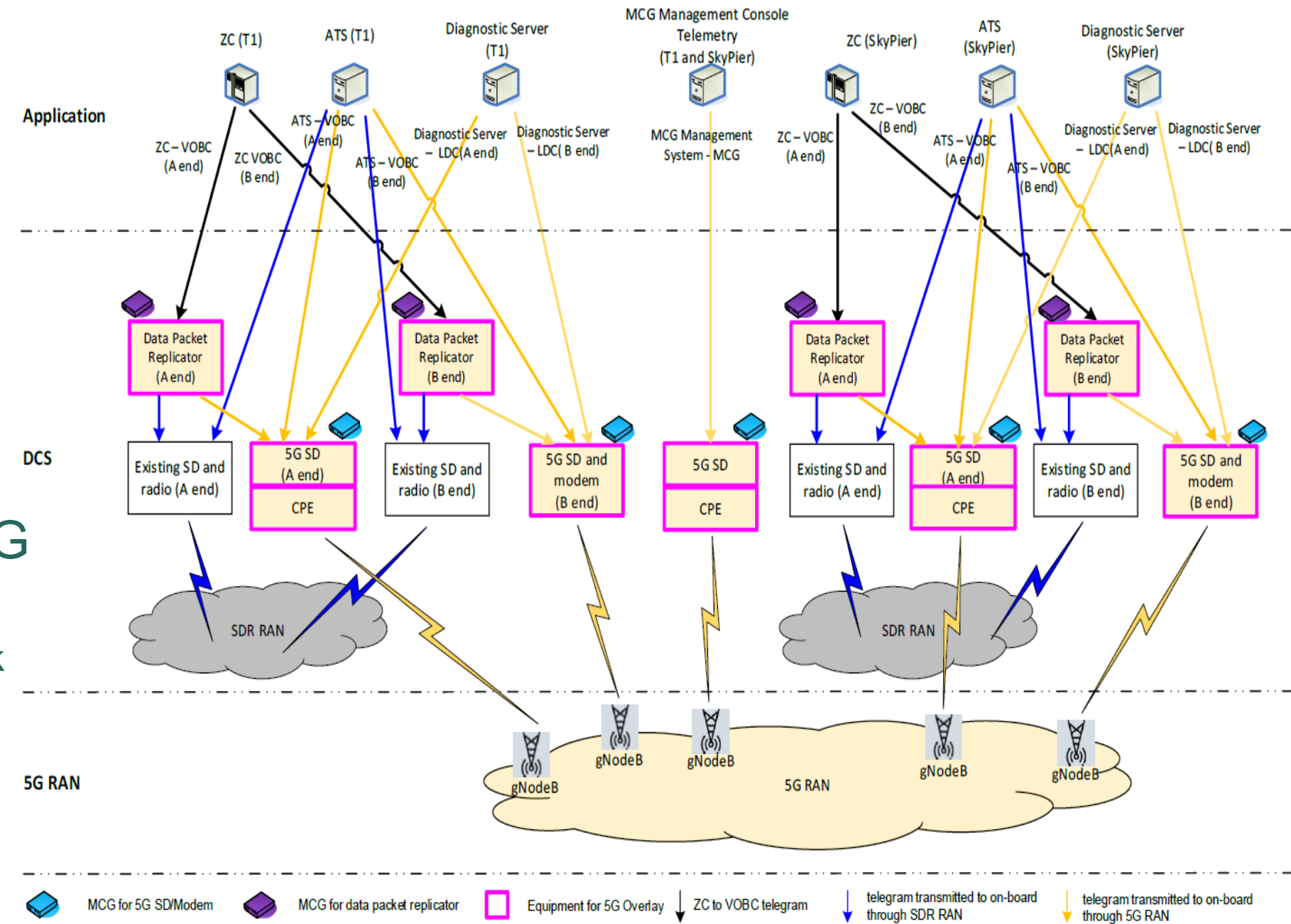

Sub-theme: Securing CBTC on HKIA APM with 5G

Hosted by:



# Standalone Train

- **Simultaneous communication layers (Private 5G and Wi-Fi)**
- Availability strengthened by redundancy between front and rear side of each vehicle.
- The MCG also **enhanced the train data collection and retrieval** via 5G network “on-the-fly” without impacting the Movement Authorizations.
- A new public key infrastructure is added for managing the certificates for the MCG security gateways.

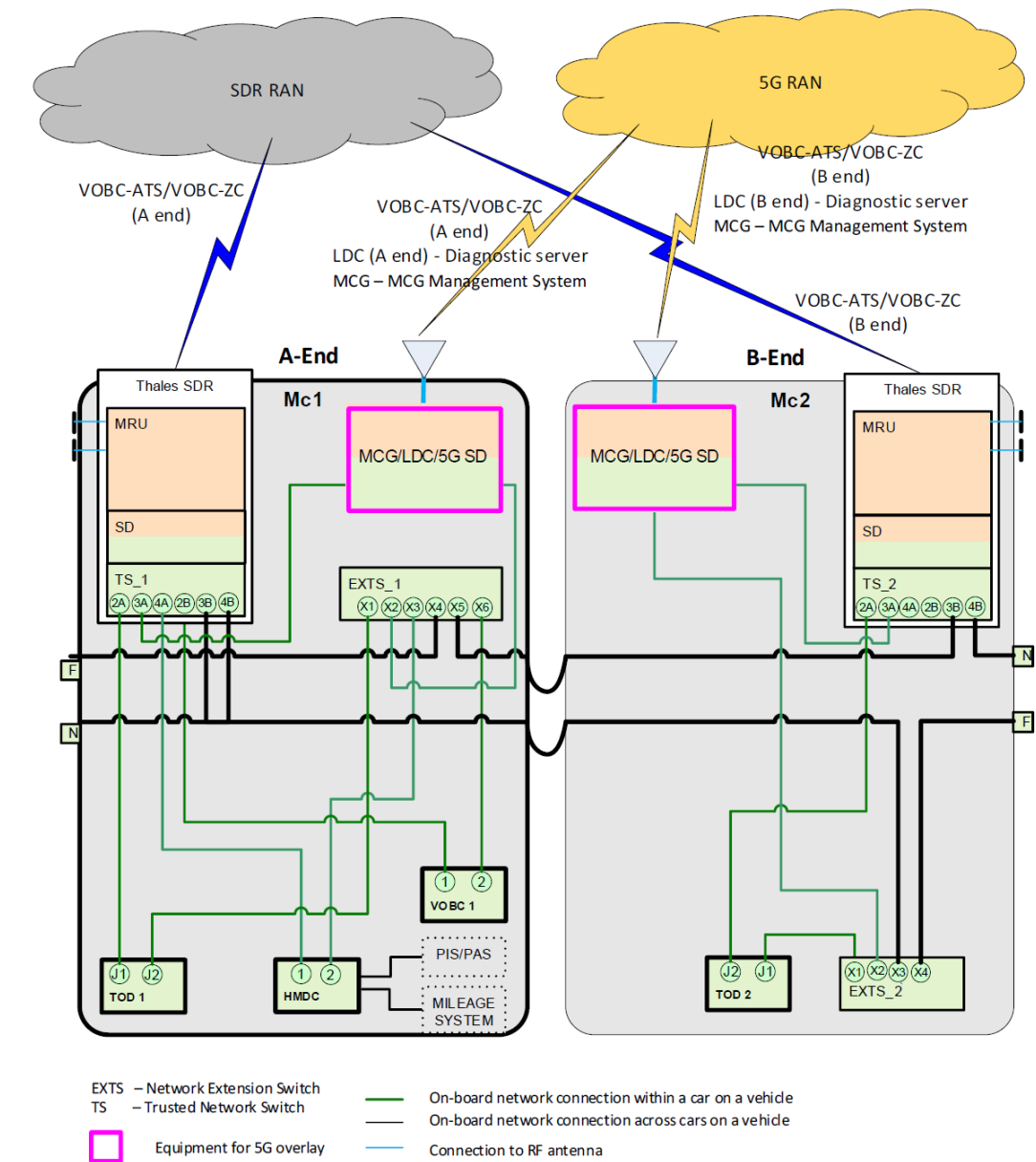

Sub-theme: Securing CBTC on HKIA APM with 5G

Hosted by:



# Coupled Trains

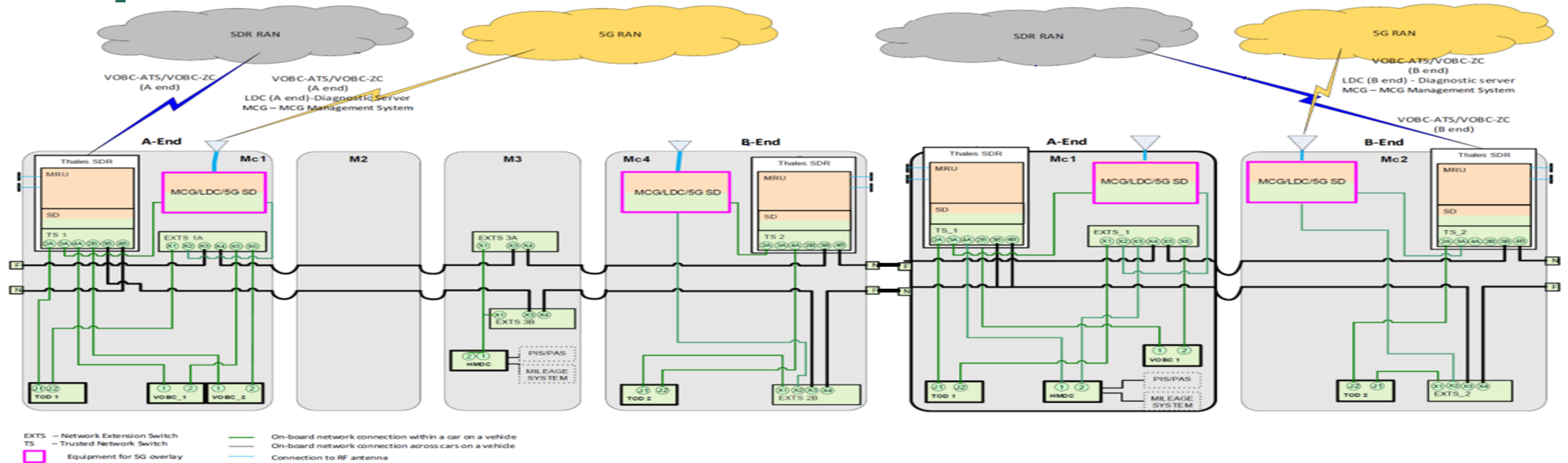

- The system will maintain redundancy by disabling coupled end MCG, coupling up to 3 vehicles together.
- It further enhance foundation of future upgrade of HMAX solution (an integrated intelligent management platform enable next level of automated operation).

# Implementation Challenges

1

**First implementation for FAO CBTC (GoA 4) without any reference project**

- A joint Proof of Concepts (PoC) collaborate with HKIA (end customer)
- An internal lab (joint onshore and offshore office) setup to fully replicated and test different operational scenarios



**The new 5G introduced cannot compromise the System Safety Integrity Level (SIL) certification, level 4**

- Early engagement with Hitachi safety authority since PoC and adjust the design accordingly



**The integration of private 5G to ensure the security as well as the performance**

- An early integration test cooperate with HKIA 5G innovation lab



**The coverage of 5G within the tunnel avoiding loss of communication because of any blind spot**

- Closely cooperation with HKIA project team and 5G infrastructure team to adjust and improve coverage with detailed coverage test

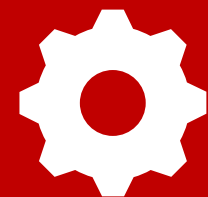

**The 5G system cut-in without impacting daily train services**

- Details rehearsal with HKIA and design of cut-in procedures in order to mitigate any risk of cut-in processes



**Sub-theme: Securing CBTC on HKIA APM with 5G**

Hosted by:



機電工程署  
EMSD



HITACHI

# Benefits

## Designed for operational excellence



High-Performance Connectivity



Ultra-Reliable Low-Latency Communications (URLLC)



Reduced Lifecycle Costs



Wireless Supervision Of Equipment



Data Analytics On The Move

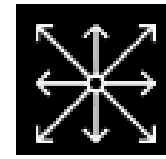

Expansion Without Limits

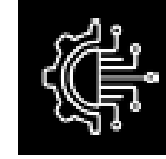

Future-Proof Technology



**Sub-theme: Securing CBTC on HKIA APM with 5G**

Hosted by:



機電工程署  
EMSD



HITACHI



# Collaboration

Hitachi Rail prioritize open communication with HKIA, actively listening to HKIA needs, challenges, and vision.

The exchange is a vital part of the continuous improvement process, helping us refine the offerings.

Hitachi Rail and HKIA work hand-in-hand to co-develop strategies and products that align with HKIA unique goals.



**Sub-theme: Securing CBTC on HKIA APM with 5G**

Hosted by:



**HITACHI**

# Collaboration

We work collaboratively at every stage, from the initial phase to the final design and implementation. This collaboration help us focused on delivering the solution on time and achieving long-term success.

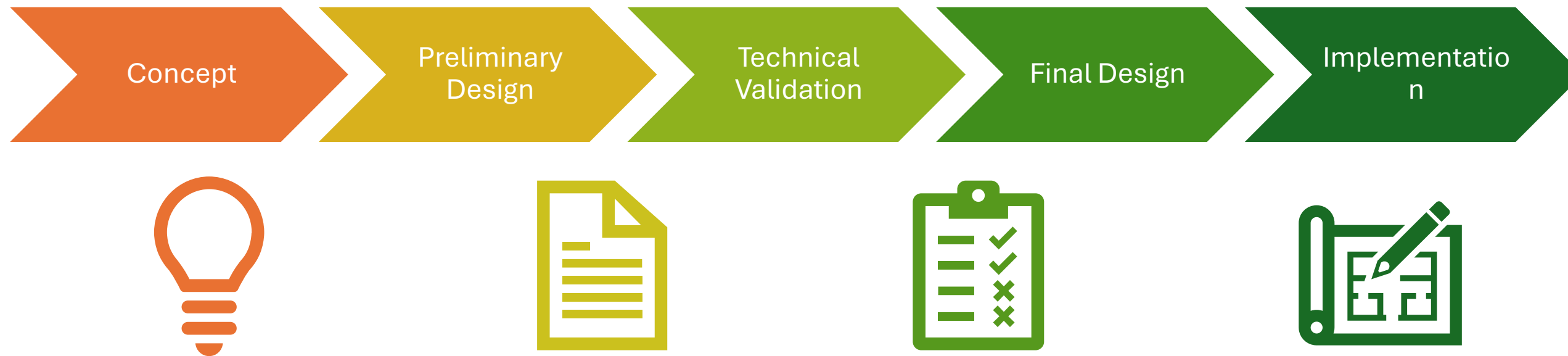

**Sub-theme: Securing CBTC on HKIA APM with 5G**

Hosted by:





**HITACHI**



[www.irsc2025.com](http://www.irsc2025.com)

Hosted by:

