



IRSC 2022

INTERNATIONAL RAILWAY
SAFETY COUNCIL

SEVILLA, OCTOBER 16-21, 2022



JEAN-CLAUDE LARRIEU

DIRECTOR RISKS, AUDITS, SAFETY AND SECURITY - S N C F



IRSC 2022
INTERNATIONAL RAILWAY SAFETY COUNCIL
SEVILLA, OCTOBER 16-21, 2022



HOW TO POPULARIZE BOW-TIE RISK ANALYSES WITHIN SNCF



IRSC 2022
INTERNATIONAL RAILWAY SAFETY COUNCIL
SEVILLA, OCTOBER 16-21, 2022



PRISME : A MAJOR SAFETY PROGRAM

P R I S M E

Proactivity

Risk management

Interfaces

Simplification

Management

Equipment

THE BOWTIE MODEL: CHOICE OF SNCF

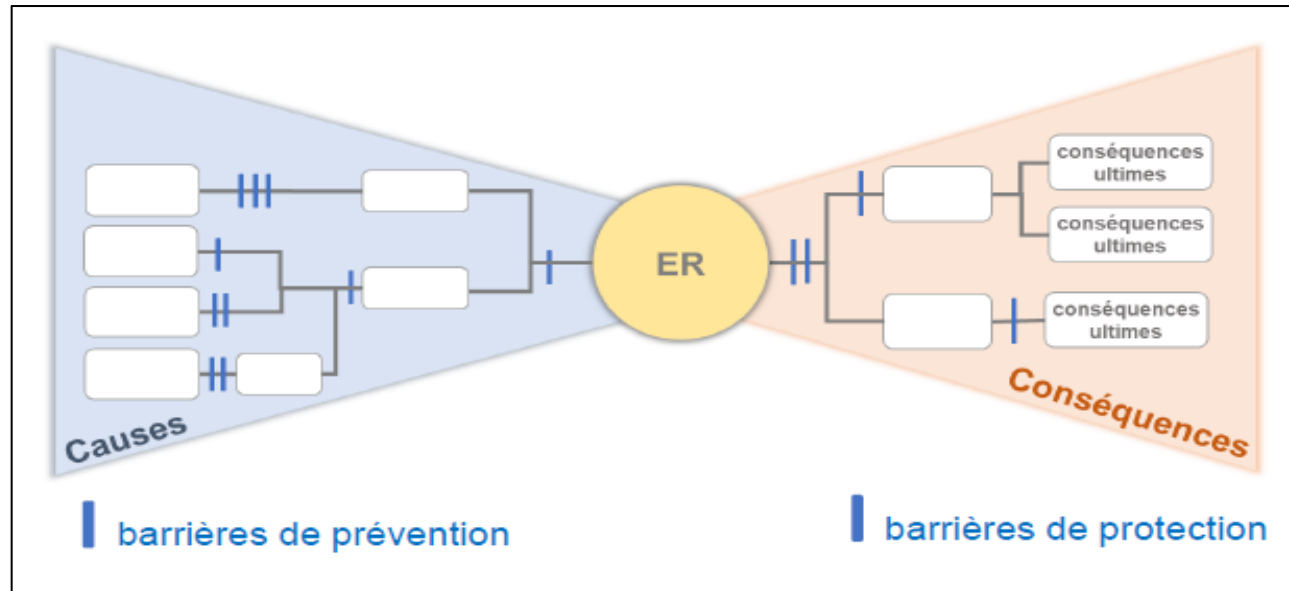



AMBITION AND METHOD



IRSC 2022
INTERNATIONAL RAILWAY SAFETY COUNCIL
SEVILLA, OCTOBER 16-21, 2022



1. THE RISKS PROJECT



2. METHOD

WHAT DO WE NEED ?



3 major needs were identified:

- develop **staff risk awareness**
- perform **efficient safety event analyses**
- allow **quantitative method**

3. A DEDICATED IT TOOL FOR BOWTIES: MARS

Modélisation et **A**nalyse des **R**isques de **S**écurité

= Safety Risks Modelling and Analysis

3. A DEDICATED IT TOOL FOR BOWTIES: MARS

M.A.R.S.

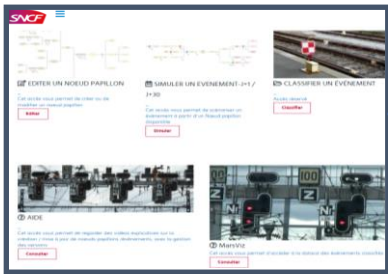

1-DESIGN

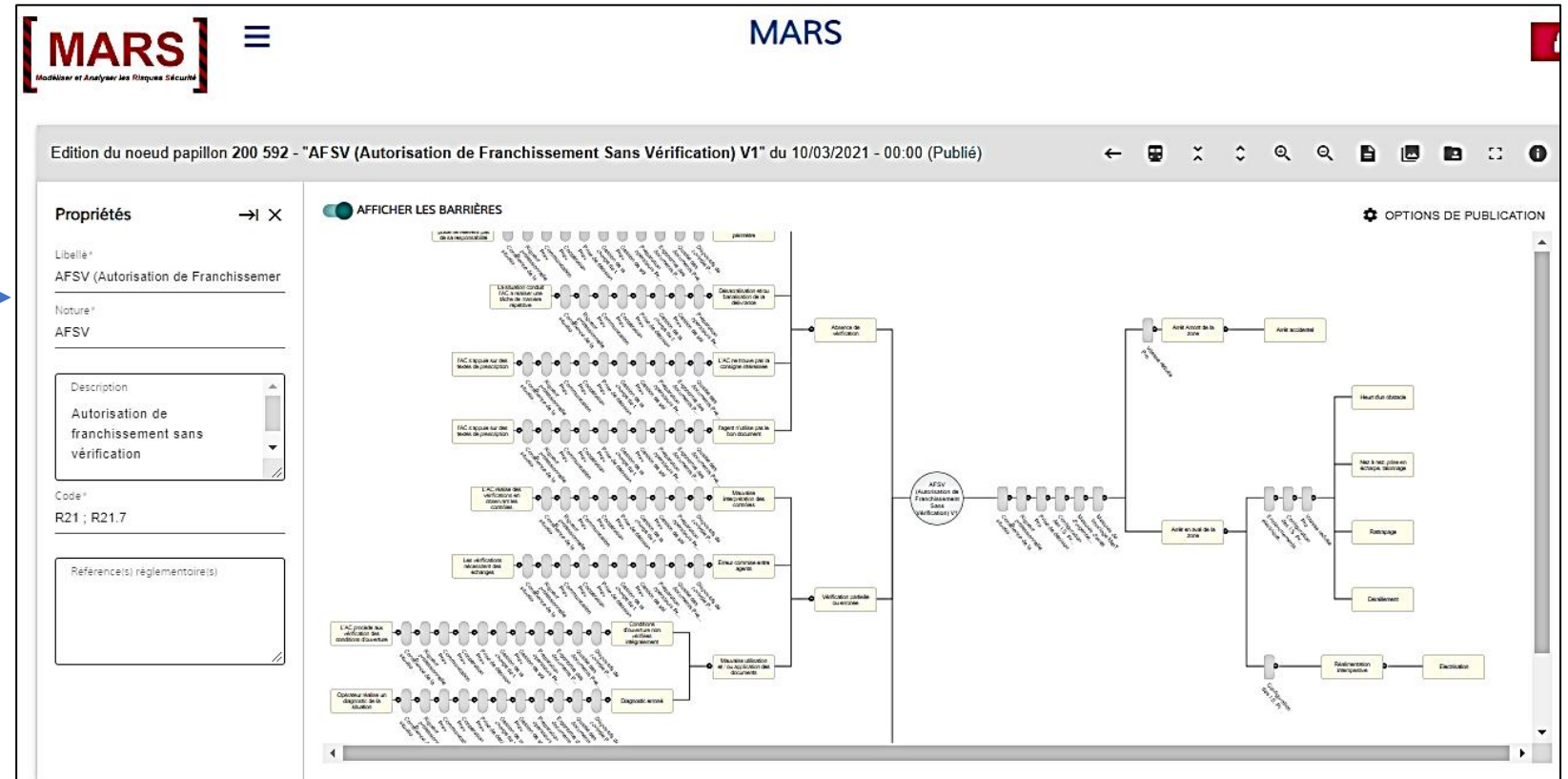

3. A DEDICATED IT TOOL FOR BOWTIES: MARS

M.A.R.S.

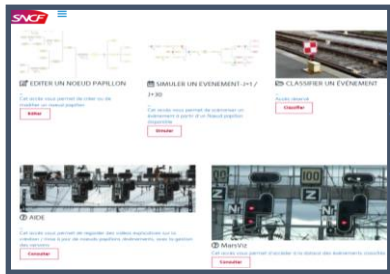

2-SIMULATION

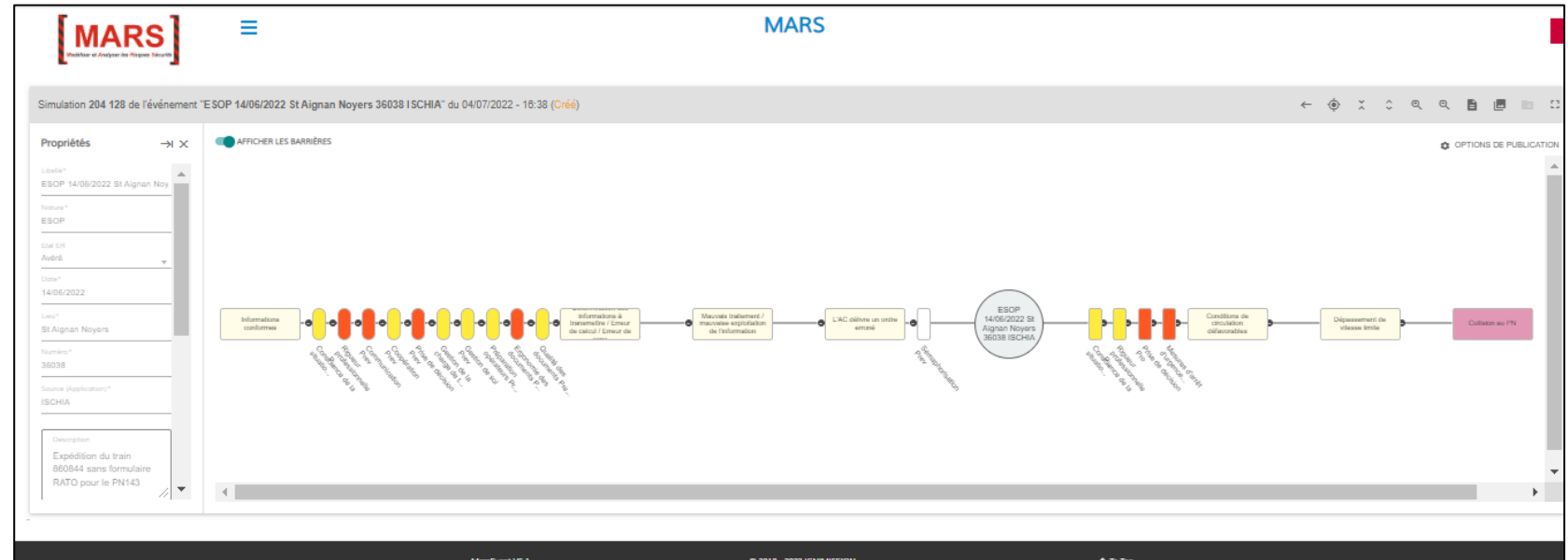

3. A DEDICATED IT TOOL FOR BOWTIES: MARS

M.A.R.S.

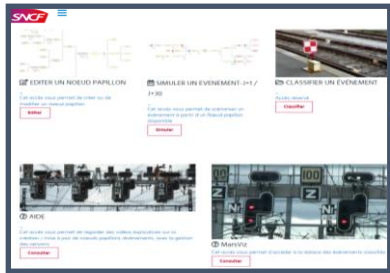

3-DATA VISUALIZATION AND ANALYSIS

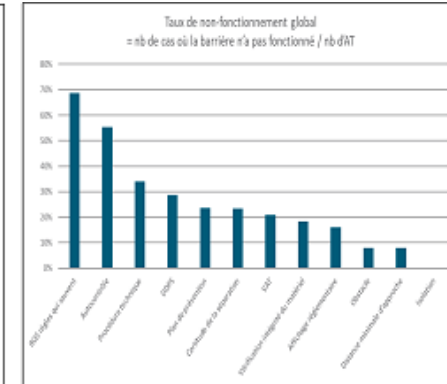
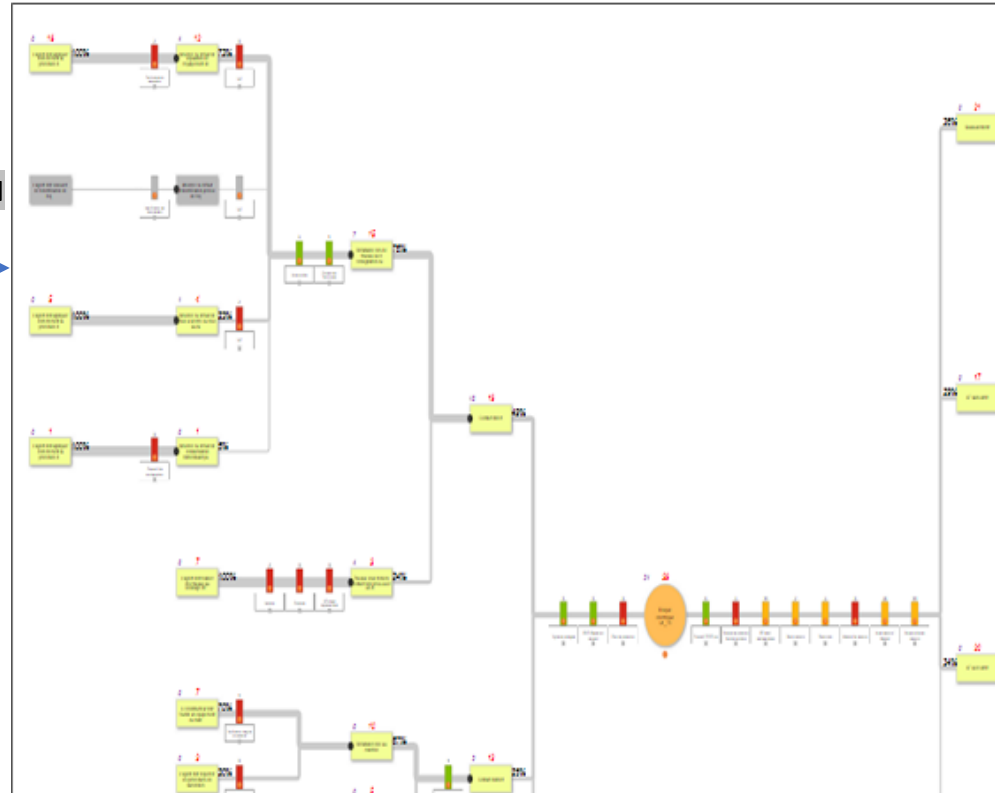

4. BUILDING A GROUP WIDE BOWTIE LIBRARY



- A library of 25 bowtie schemes (8 Health & Safety risks, 17 railway operations safety risks).

CHANGE MANAGEMENT: TRAINING & COMMUNICATION

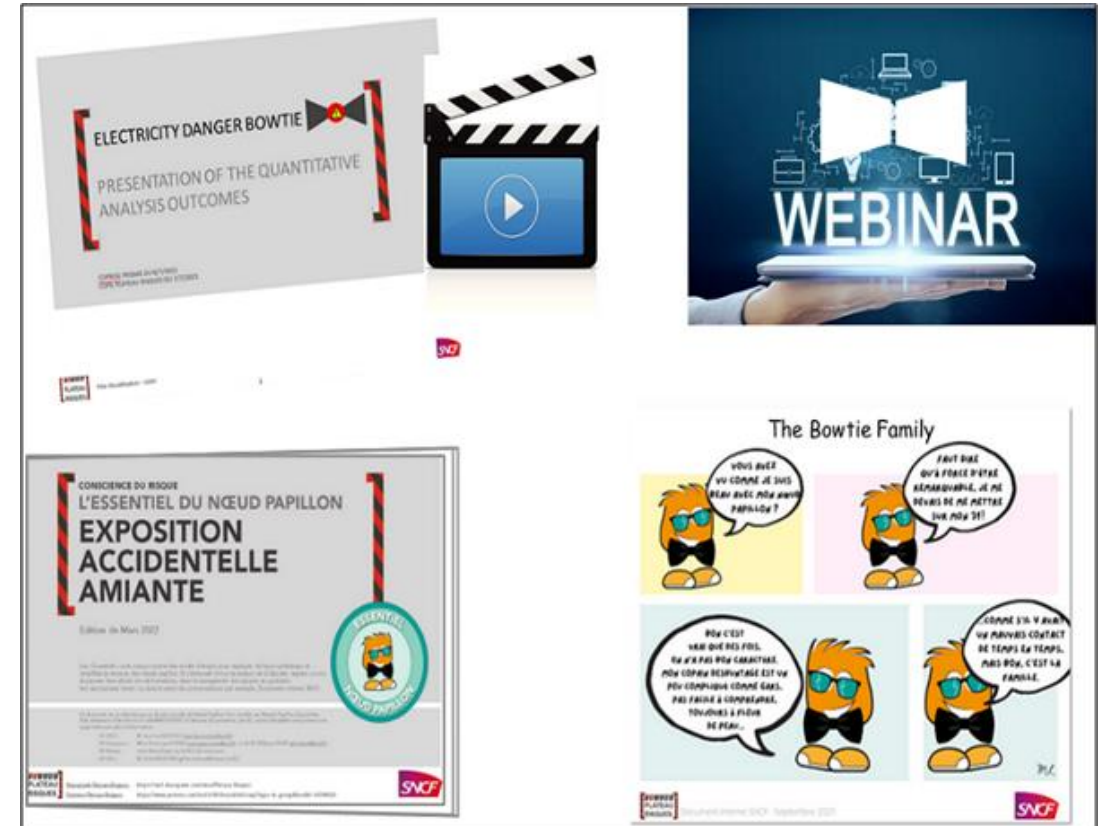
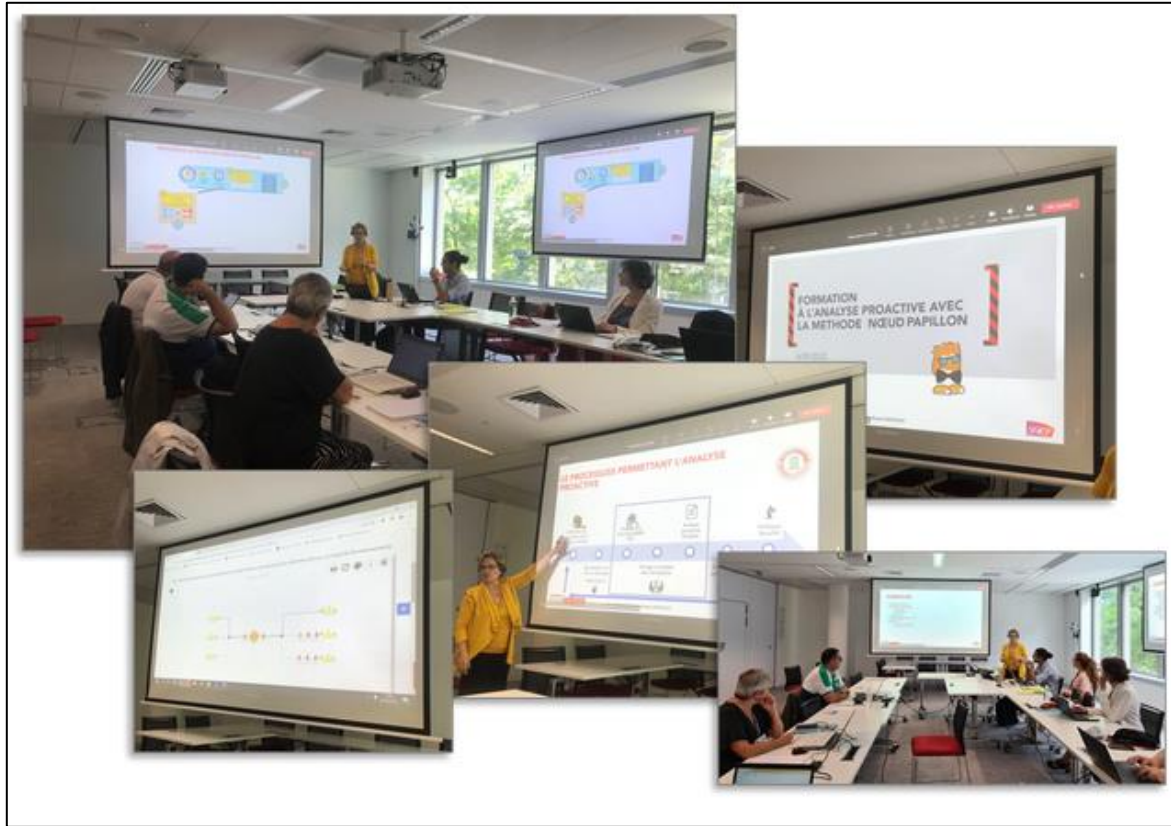

RESULTS



IRSC 2022
INTERNATIONAL RAILWAY SAFETY COUNCIL
SEVILLA, OCTOBER 16-21, 2022



RESULTS (MID 2022)

400 USERS

OVER 1000 SIMULATIONS

25 INCIDENT TYPE BOOKLETS

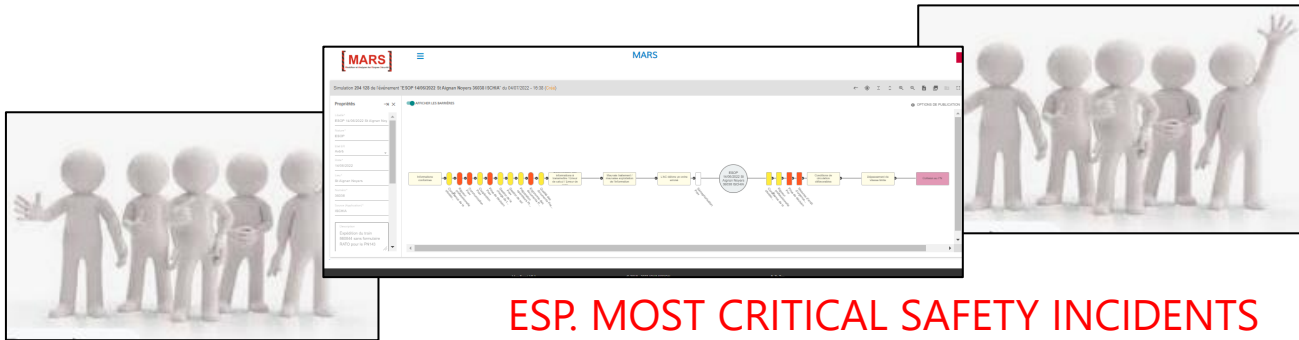

ESP. MOST CRITICAL SAFETY INCIDENTS

10 STUDIES AVAILABLE

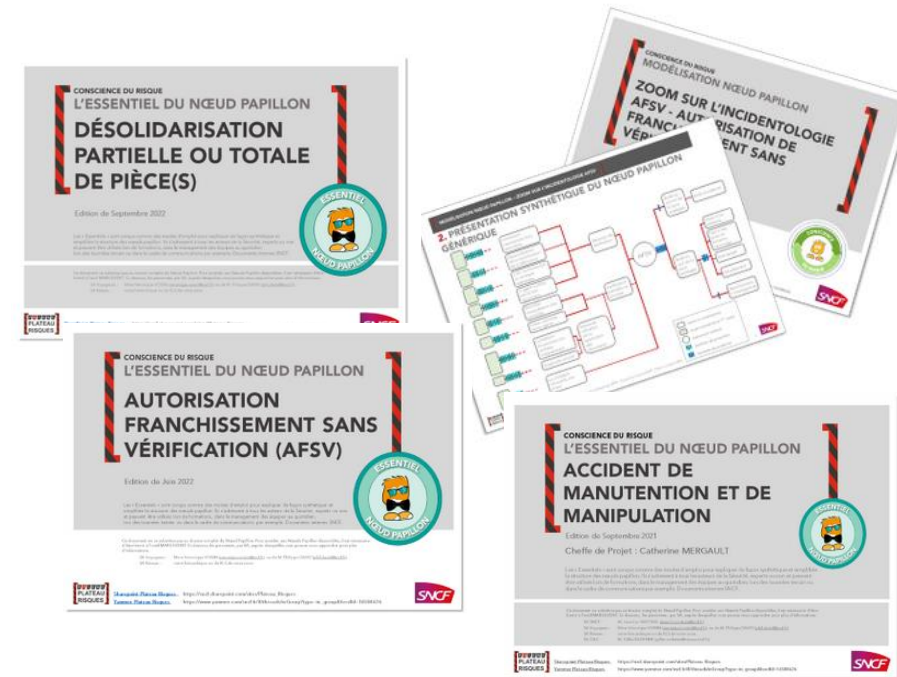

IN PROGRESS

TRAINING FOR PROACTIVE SAFETY ANALYSIS

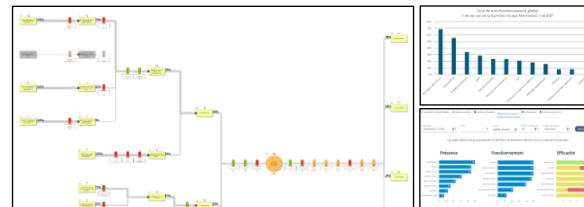

CONCLUSION



IRSC 2022
INTERNATIONAL RAILWAY SAFETY COUNCIL
SEVILLA, OCTOBER 16-21, 2022



CONCLUSION

MAIN LESSONS LEARNED



4 main pillars for a large scale, group wide project :

- **Sponsorship by top management**
- **Beginning by identifying the needs**
- **Group-wide project team**
- **Training and internal communication, using pragmatic solutions.**



www.irsc2022.com

